

PROSPECTUS

SESSION : 2023-2024



মঙ্গলদৈ মহাবিদ্যালয় : মঙ্গলদৈ

MANGALDAI COLLEGE

MANGALDAI :: ASSAM

From the Principal's Desk



Mangaldai College is a pioneer Higher Educational Institute imparting Science and Arts along with skill based B.Voc & BCA Professional Degree Programme. The college strives to build a top -notch academic environment for learners through inclusive quality education. In this connection, I take the opportunity to offer my heartiest greetings to all the respected and talented faculty members for their endeavour to make our students excel in all aspects. In compliance with the NEP- 2020, we are now trying our level best towards nurturing the holistic development for our learners.

Dr. Kamala Kanta Borah, M.Sc., Ph.D.

ABOUT MANGALDAI COLLEGE

Mangaldai College is a premier institution of higher Education in Darrang District of Assam. This institute was established in the year 1951 with the pioneering effort of late Amiya Bhushan Dasgupta, the then S.D.O.(Civil), Mangaldai and many other leading citizens of the district. The prime inspiration of these persons was to materialize the wish of the people for the spread of higher education in the district. The institution had an enthusiastic start under the leadership of the succeeding Principals, dedicated services of the faculty members and other staff contributed immensely to its growth. Now the faculty members of the college are not only devoted to their profession but also are keen to see the college flourish with brilliant performance of the students. All the teachers are endowed with extra-curricular abilities to help the students in diverse fields of games and sports, music, culture, social service and extension education. All the teachers are helpful to the students both in and outside the classroom to bring out the talent in them. The college is located at Mangaldai, the district head quarter of Darrang and on the southern edge of the N.H.-15. The college in its 33 acres of land has huge picturesque green campus with serene atmosphere. The geographical coordinates of its location is: 26025/52.19// North Latitudes and 92001/01.64// East Longitudes.

CONTACT INFORMATION

Website: www.mangaldaicollege.org
e-mail: principalmangaldaicollege@gmail.com
Phone No.- 03713-222624

OUR MOTTO

TOMOSO MA JYOTIRGAMAYA

This caption is taken from the Verse No. 37 of the Brihadaranyak Upanishad which means
"Lead from darkness (of ignorance) to light (of wisdom)"

Vision : Promotion of higher education, social upliftment and development of scientific temperament among the masses in the socially and educationally backward area where the college is situated.

Mission : To fulfil the mission of the founders, the College has set up a well-planned mission containing the following components :

Component - 1 : Inclusive Expansion of Higher Education :

- i) To encourage the enrolment of students from socially and economically deprived section of the society as the College is situated in the district declared as Educationally Backward District (EBD) and Minority Concentrated District (MCD) by UGC and MHRD, Govt. of India.
- ii) To develop the physical and infrastructure facilities to accommodate the growing number of learners.
- iii) To introduce new programmes and equip the faculty members with modern teaching - learning aids for the challenges of modern times.

Component - 2 : Development of Scientific Temperament :

- i) To encourage research activities among the students and teachers by setting up a research centre.
- ii) To encourage the students participation in developing scientific temperament in the College and nearby Schools by forming "Mangaldai College Student Science Forum" along with the existing branch of Assam Science Society.
- iii) To modernize the Science laboratories with latest equipment to meet the requirement of the changing syllabus.
- iv) To organize lecture and awareness programme on present issues with scientific explanation in the campus and nearby villages/schools.
- v) To develop the College campus a full-fledged Botanical Garden rich in Rare, Endangered and Threatened (RET), and local fruits plants of Assam.

Objectives:

- i) To promote higher education among the people irrespective of Caste, creed, religion and gender.
- ii) To create a scientifically tempered society which will exclude superstition and other evil practices which thrive because of ignorance.

COURSES OF STUDY

Two Year Higher Secondary Courses in Arts and Science Stream

Eligibility for Admission :

A student who has passed 10th standard or equivalent examination in Science and Arts stream from a recognized institution.

Reservation :

Statutory reservation policy of the Government of Assam shall be followed in case of selection of eligible candidates for admission.

Seats and Subject combination

i) Seats

Stream	Number of seats
Science	60
Arts	200

ii) Subjects

Compulsory : 1. ENGLISH 2. MIL/ALT

Elective : Education (EDUC), History (HIST), Geography (GEOG), Political Science (POSC), Logic & Philosophy (LOPH), Advance Assamese (ADAS), Sanskrit (SANS), Arabic (ARAB).

: Physics (PHYS), Chemistry (CHEM), Mathematics (MATH), Biology (BIOL), Statistics (STAS),

: Computer Science & Application (CSA)

iii) Any four from the following group of subjects (only one subject is allowed from a group)

Group-I	:	EDUC/PHYS/CSA	Group-II	:	POSC/BIOL/STAS
Group-III	:	ADAS/SANS/ARAB/MATH	Group-IV	:	ECON/CHEM
Group-V	:	HIST/GEOG/LOPH/PHYS	Group-VI	:	GEOG/MATH

N.B.: If the number of applicants for admission in each stream is below 30 (thirty) then there would be no admission in H.S. 1st year classes.

Three Year Under Graduate Programme (TYUGP)/

Four Year Under Graduate Programme (FYUGP)*

(Degree in Arts and Science Stream)

(Degree in Vocation and Computer Application)

**Subject to the approval of the University*

Eligibility for Admission:

A student who has passed 12th standard or equivalent examination in Science and Arts stream from a recognized institution.

Reservation:

Statutory reservation policy of the Government of Assam shall be followed in case of selection of eligible candidates for admission.

TYUGP/FYUGP under Gauhati University is based on the National Education Policy (NEP)2020 and Mangaldai College will follow the rules and regulations published by the Government of Assam and Gauhati University for implementation.

Introduction to TYUGP/FYUGP :

The TYUGP/FYUGP at Mangaldai College is designed by Gauhati University to offer two types of Bachelor's Degrees to the students at the end of the successful completion of the programme-

i) Bachelor's Degree in a Stream and (ii) Bachelor's Degree in a Discipline. The word stream here refers to Arts and Science. In case of a degree in a discipline, the student can take Computer Application (BCA) and Vocational B.Voc.). However, in both cases, the student studies equal number of courses (i.e. papers)-so that there is now eight age of any kind to either of the two types of degrees.

For both the types of degree programmes, course-wise, the whole TYUGP/FYUGP is divided into two parts- (i) Core Courses and (ii) Common Courses. The minimum credit allocation for a 3-year programme is 84 credits in Core Courses and 36 credits in Common Courses, which comes to a total of minimum 120 credits for a 3-year programme. With the fourth year, the minimum credit requirements becomes 160. A student can however earn upto a maximum of 132 credits in a 3-year programme and 176 by the fourth year. The details of curricula, courses and structures available at Mangaldai College are shown below :

1. Degree with Major and Minor :

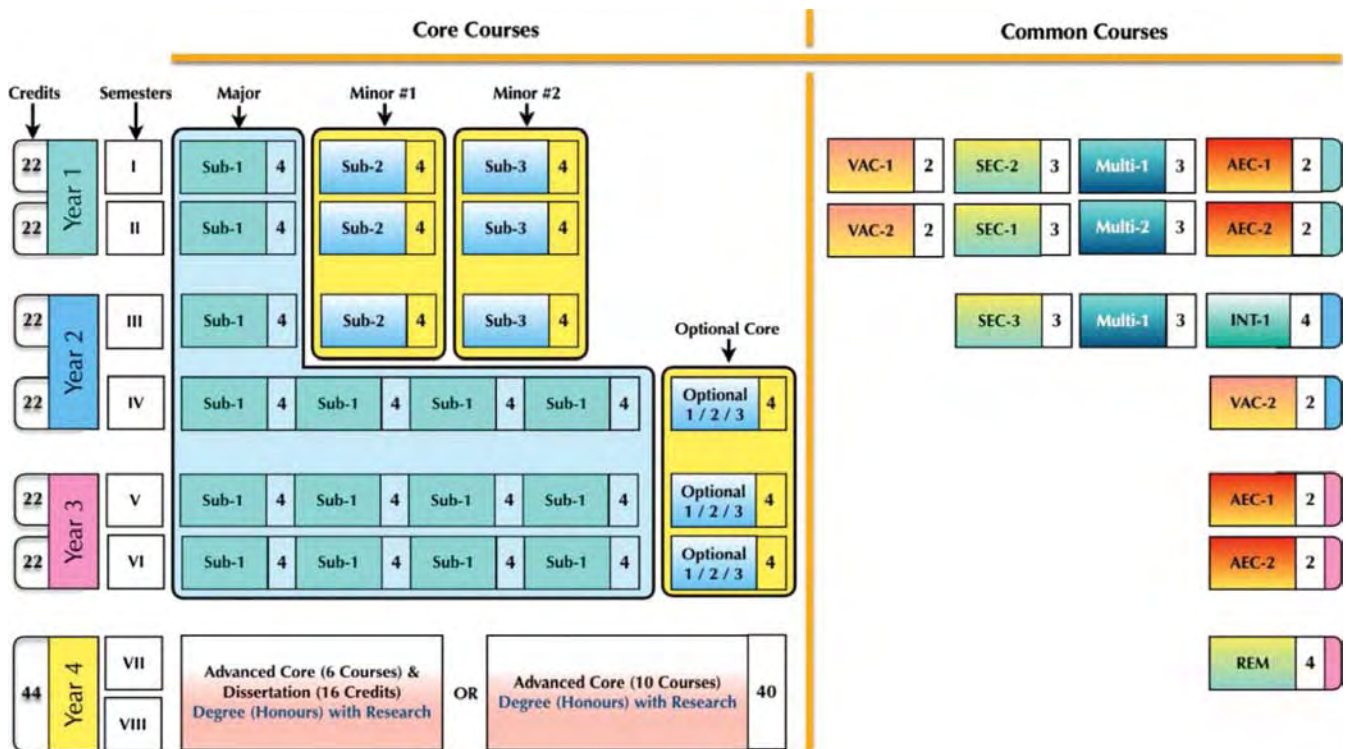

Example :

Semester	Core #1	Courses	Credits	Core #2	Courses	Credits	Core #2	Courses	Credits	Open Core Credits	Common Credits	Total Credits
I	History	1	4	Pol Sc	1	4	Economics	1	4		10	22
II	History	1	4	Pol Sc	1	4	Economics	1	4		10	22
III	History	1	4	Pol Sc	1	4	Economics	1	4		10	22
IV	History	1+3	16							4	2	22
V	History	1+3	16							4	2	22
VI	History	1+3	16							4	2	22
	History	15	60	Pol Sc	3	12	Economics	3	12	12	36	132
	Major			Minor #1			Minor #2					

2. Degree with only Minors :

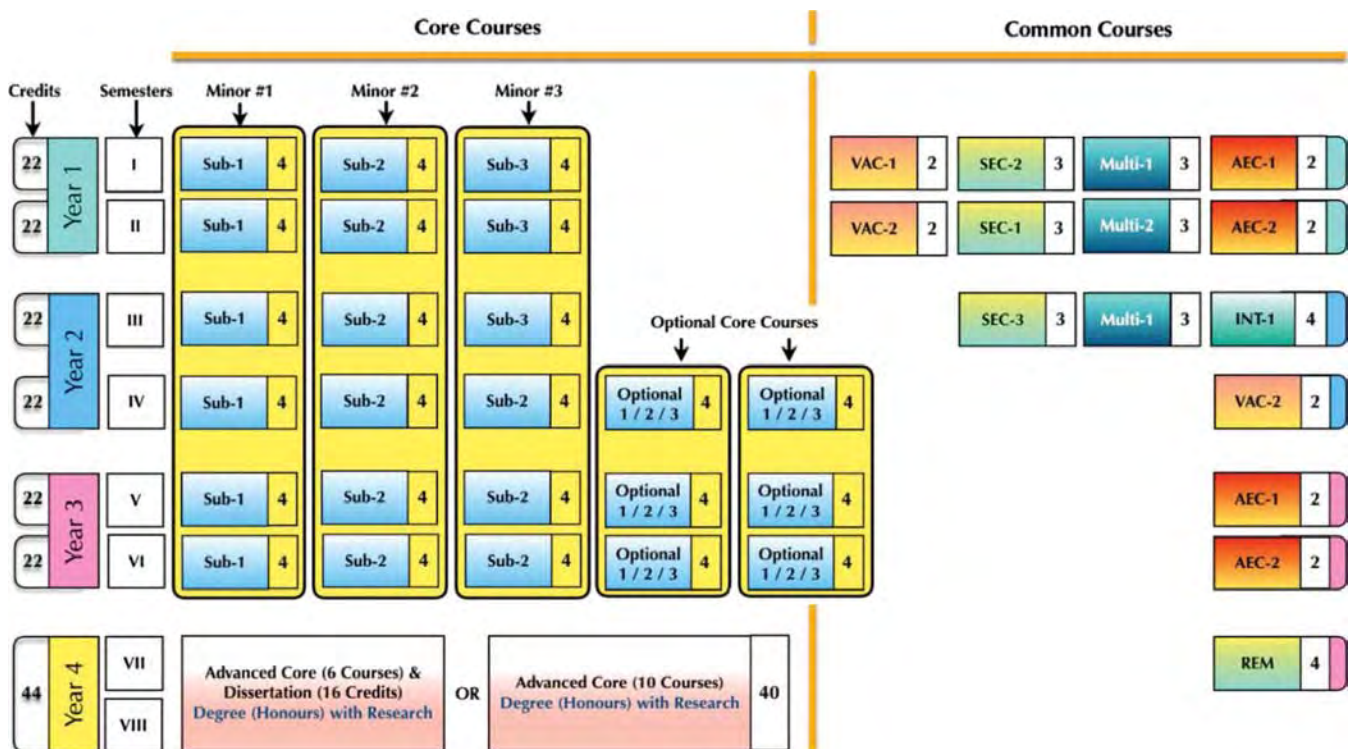

Example

Semester	Core #1	Courses	Credits	Core #2	Courses	Credits	Core #2	Courses	Credits	Open Core Credits	Common Credits	Total Credits
I	History	1	4	Pol Sc	1	4	Economics	1	4		10	22
II	History	1	4	Pol Sc	1	4	Economics	1	4		10	22
III	History	1	4	Pol Sc	1	4	Economics	1	4		10	22
IV	History	1+1	8	Pol Sc	1	4	Economics	1	4	4	2	22
V	History	1+1	8	Pol Sc	1	4	Economics	1	4	4	2	22
VI	History	1+1	8	Pol Sc	1	4	Economics	1	4	4	2	22
	History	9	36	Pol Sc	6	24	Economics	6	24	12	36	132
	Minor #1			Minor #2			Minor #3					

Core Subjects :

All core subjects available at Mangaldai College are broadly divided into two streams - Arts and Science Stream.

Degree in Arts Stream : B.A.

- This stream has three Subject Groups- (1) MIL (Modern Indian Languages), (2) Other Language, and (3) Social Science.
- A student has to select a total of three core subjects.
- The subjects BEN and BOD do not have Major option.
- The maximum number of subjects which can be chosen from each group is shown in the following table-1.

TABLE-1

ARTS (CORE COURSES)			
MIL	Other Language	Social Science	Dual Stream Subjects
Assamese (ASM)	Arabic (ARB)	Economics (ECO)	Economics (ECO)
Bengali (BEN)	English (ENG)	Education (EDU)	Geography (GGY)
Bodo (BOD)	History (HIS)	Mathematics (MAT)	
Sanskrit (SNS)	Philosophy (PHI)	Statistics (STA)	
		Political Science (POL)	
Max : 1	Max :1	Max :3	Max :2

Degree in Science Stream : B.Sc.

- This stream has four Subject Groups - (1) Physical Science, (2) Biological Science & Anthropology, (3) Earth & Environmental Science, and (4) Computer & Information Science.
- A student has to select a total of three core subjects.
- The subjects Computer Application and Information Technology do not have Major option.
- The maximum number of subjects which can be chosen from each group is shown in the Table-2.

TABLE-2

SCIENCE				
Physical Science	Biological Science & Anthropology	Earth & Environmental Science	Computer & Information Science	Dual Stream Subjects
Physics (PHY)	Botany (BOT)	Geography (GGY)	Computer Science (CSC)	Economics (ECO)
Chemistry (CHE)	Zoology (ZOO)			Mathematics (MAT)
Mathematics (MAT)				Geography (GGY)
Statistics (STA)				Statistics (STA)
Max : 3	Max :2	Max :1	Max :1	Max :2

List of pre requisites & requirements :

Following are the prerequisites for all core subjects at the entry level of the TYUGP/FYUGP i.e.at the first semester.

ARTS STREAM

MIL		
Subject	Prerequisites	Requirements
Assamese	Assamese (X-level) for Minor & (XII-level) for Major	None
Bengali	Assamese/ Bengali (X-level)	
Bodo	Bodo (XII-level)	
Sanskrit	Sanskrit (X-level)	

OTHER LANGUAGE		
Subject	Prerequisites	Requirements
Arabic	None	None
English	English(X-level)	

SOCIAL SCIENCE		
Subject	Prerequisites	Requirements
Economics	None	None
Education		
History		
Philosophy		
Political Science		

SCIENCE STREAM

PHYSICAL SCIENCE		
Subject	Prerequisites	Requirements
Chemistry	Chemistry and Math (XII-level) for Major and only Chemistry (XII-level) for Minor	None
Mathematics	Math (XII-level)	None
Physics	Physics and Math (XII-level)	Math
Statistics	Math (XII-level)	None

BIOLOGICAL SCIENCE		
Subject	Prerequisites	Requirements
Botany	Biology (XII-level)	Chemistry
Zoology	Biology and Chemistry (XII-level)	Chemistry

EARTH & ENVIRONMENTAL SCIENCE		
Subject	Prerequisites	Requirements
Geography	None	None

COMPUTER & INFORMATION SCIENCE		
Subject	Prerequisites	Requirements
Computer Science	Science and Math (XII-level)	None

Total seats at Mangaldai College :

First Semester :

1. Arts : 800 + 100
2. Science : 350 + 50

Seats in Major and Minor (Arts Stream) :

Subjects	No. of Seats (Major)	No. of Seats (Minor)
ARB (Arabic)	30	20
ASM (Assamese)	100	350
ECO (Economics)	50	100
EDU (Education)	65	350
ESL (English)	60	0
GEO (Geography)	50	180
HIS (History)	60	150
MAT (Maths)	10	20
PHI (Philosophy)	60	150
POL (Political Science)	60	350
SNS (Sanskrit)	40	80
STAT (Statistics)	10	20

Seats in Major and Minor (Science Stream) :

Subjects	No. of Seats (Major)	No. of Seats (Minor)
BOT (Botany)	60	200
CHE (Chemistry)	60	200
ZOO (Zoology)	60	200
GGY (Geography)	10	20
MAT (Maths)	60	150
PHY (Physics)	60	150
STAT (Statistics)	50	60
ECO (Economics)	20	20
CSC (Computer Science)	0	60

Discipline Specific Subject	No. Of Seats (Major)	No. Of Seats (Minor)
BCA	0	60

Discipline Specific Subject (B. VOC)	No. Of Seats
Medical Lab & Molecular Diagnostic Technology	60
Food Processing Technology	50

Degree in Discipline :

1. Bachelor in Vocation (B.Voc.)

The Bachelor's Degree in a Disciplines includes the Standalone Degrees. These degrees do not have Majors and Minors. These degrees also include Bachelor's Degree in Vocation.

Salient features:

- Has the same TYUGP/FYUGP structure - i.e., Core Courses with a minimum of 84 credits and
- Common Courses credits of 36 (in a 3-year programme).
- Students study certain pre-defined courses designed for the respective discipline.

About the programme :

The Bachelor of Vocation (B. Voc.) course is a new initiative of Government to align higher education with the emerging needs of the economy so as to ensure that the graduates of higher education system have adequate knowledge and skills for employment and entrepreneurship. Mangaldai College introduced the UGC Sponsored Bachelor of Vocation (B.Voc) course from the academic session 2015-16 in two trades namely 1. Medical Lab & Molecular Diagnostic Technology (ML&MDT) and 2. Food Processing Technology (FPT). The B.Voc programme at Mangaldai College is designed to bridge the gap between traditional education and the evolving job market, providing students with specialized vocational skills and knowledge. Our dedicated faculty and state-of-the-art facilities ensure a dynamic learning environment, allowing students to gain hands-on experience in their chosen field.

About Medical Lab & Molecular Diagnostic Technology:

Medical laboratory technology is one of the most rapidly expanding health care fields. The course offers a comprehensive understanding of the role of medical laboratories in healthcare. It focuses on the application of molecular diagnostic technology, which has revolutionized disease diagnosis and treatment. According to National Skill Development Council (NSDC) report there is a huge gap of skilled Medical Lab professionals all across the country. Mangaldai College introduce professional skill-based course like Medical Lab & Molecular Diagnostic Technology emanate like an opportunity for the students and aspiring professionals in the sector of Healthcare Industry. The course combines theoretical knowledge with hands-on training to prepare students for a successful career in medical laboratory science.

No. of intake: 50

Fees: 7000/- (Per semester)

For First Semester:

Core Paper will be as -

MED-101 : Human Anatomy & Physiology (3+1 = 4 Credits)

MED-102 : Introduction to Biomolecules, Instrumentation & Reagents (3+1 = 4 Credits)

MED-103 : Introduction to Pathology (3+1 = 4 Credits)

About Food Processing Technology:

Food processing is a contemporary exercise that develops efficiency and improves promotion of the food products. This course is based on developing set of methods and techniques which can be used to transform raw materials into nutritious and safe food for consumption. Despite the fact that food processing industry in India is at a developing stage, it offers exponential career opportunities to train professionals in food processing. The curriculum has been designed to include general education and skill development components, having extensive practical and on job trainings along with regular industrial visits so that they can be easily absorbed in Food Industry or become Entrepreneurs.

No. of intake: 50

Fees: 7000/- (Per semester)

For First Semester:

Core Paper will be as -

FPR-101 : Food Processing I (3+1 = 4 Credits)

FPR-102 : Bio-resources in Food Processing (3+1 = 4 Credits)

FPR-104 : Food Plant Sanitation and Hygiene Management (3+1 = 4 Credits)

2. Bachelor's Degree in Computer Application(BCA)

About the Programme:

BCA programme has been introduced in Mangaldai College since 2017-18 session. The BCA program enhances students' critical thinking, logical reasoning, and analytical abilities for solving IT problems. Graduates are well-equipped for various career paths in education, research, government, business, and industry. The comprehensive curriculum covers essential computer science concepts such as data structures, algorithms, software engineering, programming languages (C, C++, Java, python etc), computer networking, system administration, operating systems, web technology, computer graphics, and database management systems. Additionally, students gain hands-on experience in computer labs, working with programming languages and tools, exploring emerging trends like mobile applications and data mining.

Eligibility: The candidate must have passed Higher Secondary or equivalent level examination from Science/Commerce/ Arts Stream. Students who have passed the Higher Secondary examination with either Mathematics or Computer Science as one of the subjects obtaining minimum pass mark in the subject should be given preference at the time of admission. Students completing Diploma in CSE/IT from AICTE recognized institutes are also eligible for taking admission.

No of Intake: 80 (Sixty) seats.

Fees: 10,000/- (Per Semester)

Programme Structure of Bachelor's Degree in Computer Application.

Semester	Paper Name	Course type	Credit
I	Computer Fundamentals	Compulsory	4(3+1)
	Introduction to C-Programming	Compulsory	4(3+1)
	Mathematics I	Compulsory	4
II	Data Structures & Algorithms Using C	Compulsory	4(3+1)
	Digital Logic Fundamentals	Compulsory	4
	Mathematics II	Compulsory	4
III	Computer Organization and Architecture	Compulsory	4
	System Software	Compulsory	4(3+1)
	Object Oriented Programming through C++	Compulsory	4(3+1)
IV	Database Management System	Compulsory	4(3+1)
	Operating system	Compulsory	4(3+1)
	Automata Theory and Languages	Compulsory	4
	Python Programming	Compulsory	4(3+1)
V	Software Engineering	Compulsory	4
	Web Technologies	Compulsory	4(3+1)
	Java Programming	Compulsory	4(3+1)
	Computer Networks	Compulsory	4(3+1)

VI	i)Computer Graphics	Elective I	4(3+1)
	ii)Information Security and Cyber Laws		4
	iii)Computer Oriented Numerical and Statistical Methods		4
	i)Artificial Intelligence	Elective II	4(3+1)
	ii)Advanced Web Programming		4(3+1)
	iii)Data Mining and Warehousing		4(3+1)
	i)Optimization Techniques	Elective III	4
	ii)Mobile Application Development		4(3+1)
	iii)Graph Theory		4(3+1)
Project	Compulsory	4	

Degree in a Disciplines

Common Course

Core courses

Credits	Semesters	Core 1	Core 2	Core 3
22	Year 1	Sub -1 4	Sub-2 4	Sub-3 4
22		Sub -1 4	Sub-2 4	Sub-3 4
22	Year 2	Sub -1 4	Sub-2 4	Sub-3 4
18		Sub -1 4	Sub-2 4	Sub-3 4 Sub-4 4
18	Year 3	Sub -1 4	Sub-2 4	Sub-3 4 Sub-4 4
18		Sub -1 4	Sub-2 4	Sub-3 4 Sub-4 4

The Common Courses are same for all.

Common Courses for B.A., BSc, B. Voc. And BCA :

1. Value Added Courses (VAC)
All students need to take two VACs of 2 credits each during Semester I, II & IV.
2. Skill Enhancement Courses (SEC)
All students need to complete three SECs, each with 3 credits during Semester I-III.
3. Ability Enhancement Courses (AEC)
All students need to take four AECs of 2 credits each during Semester I, II, V & VI. However, students with a Major/Minor in MIL subject cannot choose MIL as AEC of the same subject.
4. Multidisciplinary Courses (MDC)
All students need to take three MDCs of 3 credits during Semester I-III, which are class-XII level courses.

Semester-wise Common Courses distribution for TYUGP/FYUGP for both Degree in Stream and Discipline

Semester	VAC	SEC	AEC	MDC
I	VAC-1 EVE-101 Environmental Studies	SEC-2	MIL AEC-101 Assamese - I AEC-102 Bengali - I AEC-103 Bodo - I AEC-108 Alternative English - I	MDN-101 for Arts (Natural Science - I); MDH-101 for Science (Humanities and Social Science-I)
II	VAC-2 HYS-151 Yoga for Well being	SEC-1	AEC-151 English Communication - I	MDN-151 for Arts (Natural Science - II); MDH-151 for Science (Humanities and Social Science-II)
III	-	SEC-3	-	MDN-201 for Arts (Natural Science - III); MDH-201 for Science (Humanities and Social Science-III)
IV	VAC-2 IND-253 Studies in Language in India	-	-	-

V	-	-	MIL AEC-301 Assamese - II AEC-302 Bengali - II AEC-303 Bodo - II AEC-108 Alternative English - II	-
VI	-	-	AEC-351 English Communication - II	-

Internship:

All students are to carry out an Internship with a credit allocation of 4. The internship can be carried out in any semester during Semesters III-VI. As internships are meant to be done during semester breaks, they will not interfere with other classes.

The fourth year :

In the FYUGP, the fourth year is at par with the first year of a Master's programme, as a student can directly can take admission into the second year of a Master's programme after the successful completion of the FYUGP.

In the fourth year, a student has to complete one compulsory paper on Research Method- ology (REM) in the Semester VII, which is a 4-credit theory paper. The rest of courses will consist of Advanced Core Courses and a Dissertation. The detailed structure for the fourth year will be published soon.

Important Points :

1. Exits & Entries

Under CBCS, one needs to complete the full 3-year programme in order to get a degree. There is no provision for dropping out of the programme in the middle. While in the FYUGP, one has choice to exit from the programme thrice-after one year, after two years, and after three years. If one exits the programme after one year, one gets a certificate. If one exits after two years, one gets a diploma. If one exits after three years, one gets a Bachelor's Degree. And finally, if a student completes the whole 4-year, one gets a Bachelor's Degree (Honours).

Note- If you exit in the middle, the doors are still open for you to enter into the programme again and you can start the journey from where you left. Every students who wants to exit before 3 years into the programme, MUST complete an additional Vocational Course of 4 credits.

2. Progression

If a student exits the FYUGP after 3 years, s/he will need to take admission into the first year of a Master's programme, which is a 2-year degree programme. However, if a student fully completes an FYUGP, s/he needs to take admission into the second year of a Master's programme and needs to complete only one year to get a Master's Degree.

3. Progression to Doctoral Studies

Once a student takes admission into a Master's programme either after 3 years of the Bachelor's programme or after FYUGP, one will be able to take admission into a Doctoral programme leading to the Degree of PhD. However, if a student is exception-ally good, one can directly take admission into a Doctoral programme right after the FYUGP, by passing the Master's programme.

4. First Year (Semester I & II)

In the first year, one studies three different core subjects-one paper of each subject per semester and a host of common subjects as described already.

5. Second Year (Semester III & IV)

In the third semester, one will usually continue with the same core subjects that have already been chosen in the first year and again study some common subjects. In the third semester, one will also take a step forward to study the favourite subject by declaring one of the core subjects as a Major subject and other two as Minors. However, the structure of the programme remains same as in first & second semesters.

From Semester IV onwards, one will primarily study the Major subject by taking at least four papers, some of which may be elective depending on the subject concerned. As the programme structure in the third semester is same as the first & second semesters, one will have the option of changing the Major in fourth semester to any one of the other two Minors as well, even if one has already declared a Major in the third semester. However, this has the condition that the new Major subject of choice has vacancy.

6. Third Year (Semester V & VI)

In the third year, one will continue to study the Major subject to complete a full set of 15 papers in Majors.

7. Fourth Year (Semester VII & VIII)

If one intends to progress to the fourth year, s/he will be devoting the time in studying advanced courses which will be at the level of initial Master's degree papers. Besides, one will also have the opportunity of engaging into research work with the faculty members.

Note- If a student like to change a Minor subjects in the third semester, he/she can change with the following limitations:

a) *He/she will be able to change a subject, provided the new subject can accommodate you. This can be a problem with science subjects as they need to ensure laboratory space for each student.*

b) *Besides, as the student has already abandoned the first year time studying a subject which you no longer want to continue, he/she will need to use your open core credits to compensate for the new subject.*

8. Open Core Credits (Free Credits)

From fourth to sixth semester, one will have time for 4 optional open core credits per semester, which one can utilise to study either of the Major or two Minors. They can also come handy, if one had changed a Minor subject in between.

9. Double Major

If a student is ready to do some more hard work, s/he can take some extra online courses (from designated sources only) related to the Minors and can then convert one of the Minors to a second Major by the time one completes 3 / 4 years of study. This is over and above the first Major. In this case, one will have a Bachelor's Degree with Double Major.

10. Semester-wise Credit Requirements

The complete FYUGP consists of 8 semesters, to be completed in a minimum of 4 academic years. Each academic year has two semesters. Each semester has a maximum credit allocation of 22. The credit requirements for GU's FYUGP is as follows:

- (a) Semester I:22
- (b) Semester II:22
- (c) Semester III:22
- (d) Semester IV:22
- (e) Semester V:22
- (f) Semester VI:22
- (g) Semester VII : 22
- (h) Semester VIII : 22

Total : 176 (Including 12 Open Core Credits i.e. Free Credits earned during Sem. IV-VI)

11. *Classes*

In GU-TYUGP/FYUGP, during the course of a semester, the word 'class' means contact hours of teaching. The classes are divided into two groups- (i) Theory and (ii) Practical. Both theory and practical classes can either be Contact Classes or Non-Contact Classes. Contact Classes are those classes which are carried out in a class room or in a laboratory. All other classes will termed as Non-Contact Classes.

All classes that a student attends are ultimately converted to academic credits. The following should be noted-

- (a) The allotment of a credit for certain course (i.e. paper) is for the duration of a Semester.
- (b) In GU-FYUGP, all credits are calculated on a weekly-basis and one week is a span of days starting from one Monday to the next Sunday. The conversion from credit to contact hour of teaching is as follows.
1 Credit = 1 Hour of Theory Class OR
1 Credit = 2 Hours of Practical Class
- (c) The 'Theory Class' can be any of (i) A Teaching Class in a Classroom, (ii) A Tutorial Class, or (ii) Assignments.
- (d) The 'Practical Class' can be either (i) A Practical Class Conducted in a Laboratory or (ii) A Project Work.

12. *Conversion to class hours*

It is expected that in the course of a Semester, a minimum of 15 (fifteen) weeks worth of classes should be conducted. So, a 4-credit theory course should have a minimum of 60 hours of teaching in a Semester, which roughly translates to 15 one-hour theory classes. The following examples explain this conversion in details for a whole Semester.

- a) A course with 4 Theory Credits
 $4 \times 15 = 60$ Hours of Teaching
- b) A course with 3 Theory and 1 Practical Credits
 $3 \times 15 + 1 \times 30 = 75$ Hours of Teaching
- c) A course with 2 Theory and 2 Practical Credits
 $2 \times 15 + 2 \times 30 = 90$ Hours of Teaching
- d) A course with 4 Practical Credits
 $4 \times 30 = 120$ Hours of Teaching

13. *Inter-institution mobility*

The GU-FYUGP allows a student for inter-institutional mobility, both for incoming and out going students. For this, GU will take into account the credits a student has in his /her ABC.

For an incoming student, the following should be observed:

- (a) The entry is subject to availability of seats in the concerned discipline.
- (b) The student need to fulfil all the academic prerequisites of the concerned discipline.
- (c) Gauhati University will award a degree to a student, only when the student will have completed 60% of the credits for core courses from GU.

14. *Academic Bank of Credit (ABC)*

- ABC or the 'Academic Bank of Credits' refers to the initiative of the Ministry of Education, Government of India where a student's academic credit is consistently deposited in to the ABC.
- All prospective students who wish to take admission into the GU-TYUGP/FYUGP, either through an affiliated college or through the FYUGP @ GU Campus, must be registered with the ABC and must obtain the 12-digit ABC ID through the Digilocker platform.
- Students are encouraged to visit the ABC Website for all related information which are available along with video tutorial.
- The students should obtain the ABC ID prior to admission into the GU-TYUGP/FYUGP. GU shall require the ABC ID of each and every student admitted into the GU-FYUGP either at the time of Registration or at the time of Downloading of the Admit Card for the First Semester examination.

IN OUR COLLEGE

1. Internal Evaluation would be based on the basis of compulsory Sessional Examinations, home assignments, seminars and library work in each semester. Internal and External examinations carry 20% and 80% of total marks respectively.
2. External Evaluation would be based on the final examination to be held at the end of each Semester.
3. The pass mark in each theory paper is 30% & in each practical paper it is 40%.
4. In each paper, students must secure pass marks in both the internal as well as the external evaluation separately.
5. A student who could not appear or failed in any semester examination will be allowed to clear the same as follows:
 - (a) First Semester with the regular third semester examination
 - (b) Second Semester with the regular Fourth Semester examination
 - (c) Third Semester with regular fifth semester examination
 - (d) Fourth Semester with regular Sixth Semester examination.
6. A student may be allowed to "repeat" any one of the theory papers in the First, Second, Third and Fourth semester and may be allowed for "betterment" of marks in one paper in the Fifth Semester, provided the student secures less than 45% marks in that paper.
7. No 'repeat'/'betterment' shall be allowed in the practical examinations in any semester.
8. A student must pass all his semester examinations, including "repeat" and "betterment" chances to clear a particular semester.
9. In case of any dispute regarding evaluation or unforeseen event the matter may be placed in the Committee of Courses and Studies (U.G) for amicable settlement.
10. Since the Semester system involves continuous assessment there would be no scope for a student to appear as a private candidate in any subject.
11. For any matter not covered under this Regulation for Semester System, the existing University Rules and the Gauhati University Act. 1947 (as amended till date) would be applicable. As regards, the existing CBCS System and newly NEP-2020 implemented TYUGP/FYUGP, the college will follow all the directions of the GU as and when they are intimated.
12. Appearing in the Sessional Examination is compulsory.

ADMISSION PROCEDURE

A candidate willing to take admission in this college must apply through prescribed ONLINE APPLICATION FORM in the **SAMARTH PORTAL & COLLEGE PORTAL** after reading the following prescribed procedure and the prospectus carefully. Provision of reservation will be made as per rules of the Government.

Admission will be made strictly on the basis of merit. A merit list of candidates will be available in the College Website before admission. Detail procedure is cited at the last page.

DATES OF ADMISSION:

B.Sc. 1st Semester	:	05, 09 & 13 July, 2023
B.A. 1st Semester	:	06, 07, 10, 11, 14 & 15 July, 2023
B.Voc & BCA	:	29 June, 2023
HS 1st Year Arts & Science	:	As per the AHSEC notification

Candidates selected for admission must upload the following documents

1. Pass certificate from the Head of the institution last attended
2. Original marksheets of all qualifying examinations appeared
3. a) Admit card of HSLC, b) Registration certificate of the last examination appeared, c) Caste/Tribe/Physically challenged certificate, d) Original certificate of awards/ participation in National/State/District/University level games and sports/art, cultural activities, e) Gap period certificate /affidavit regarding activities in the break period
4. One recent passport size photograph.
5. Candidates from other state are required to submit domicile certificate from competent authority.

GENERAL INFORMATION

1. *Identity Card*

The college identity card is issued to the students at the time of admission and it remains valid for one academic year. At the time of renewal of admission, fresh Identity Cards will be issued every year by the authority concerned. In case of any loss or damage of the card the matter should be immediately brought to the notice of the Principal and the duplicate Identity card would be issued on application after proper verification.

2. *Attendance*

Attendance in classes is compulsory. Attendance of the students will be recorded online from 2023-2024. A student will be debarred from appearing as a regular student in any examination conducted by AHSEC and the Gauhati University if he/she fails to attend at least 75% of lecture delivered in each subject of his/her combination. A student will be penalized if he/she fails to attend 75% of classes and will be considered as a non-collegiate student. A non-collegiate student will have to pay a fine of Rs. 3000.00 along with supporting documents to appear in the final examination.

3. *General Rules for Maintenance of Discipline*

- a) Only those associations recognized by the College authority can avail the facilities of the College premises.
- b) Notice of any kind for circulation must be approved by the Principal.
- c) Principal's signature on Identity Card shall be affixed within 15 days from the date of admission.
- d) Students must keep the Identity Card with them in the college campus and produce it whenever demanded.
- e) Filled up Registration Form of Council/University should be submitted in the office within the stipulated time as fixed by the college office. No registration form will be received after such time.
- f) For a Pass Certificate from the college, one has to apply one day in advance and for a Transfer Certificate, he/she has to apply at least two days in advance.
- g) The responsibility for maintaining discipline is vested with the Principal and the Disciplinary Action Committee. Their decision shall be final in all such matters. Recently promulgated Govt. Rules on ragging are strictly adhered to in our college. Students will be punished for indulging in such activities as given in the following:
 - Encouraging and participation in ragging of any type.
 - Forcible disruption of classes.
 - Destruction of college properties.
 - Misbehavior shown towards girls, women, and teaching and non-teaching employees of the college.
 - Using drugs, narcotics and cigarette smoking inside the college campus.
 - Misleading the college authority by providing wrong information.
 - Damage of library books, desks-benches and other property in possession of college.
 - Any kind of activity which is detrimental to the academic atmosphere of the college.

4. *Uniform*

Wearing of College Uniform is compulsory for all students.

Uniform for Boys : Formal black trousers (low waist trousers/jeans not allowed), sky-blue shirt, maroon sweater or blazer, black shoes, black foot wear.

Uniform for Girls : White dupatta, sky-blue kameez (below knee), white salwar (No slacks and leggings allowed) or sky-blue sari, white blouse, Maroon sweater or blazer, black shoes/ black foot wear or sky -blue chadar, sky-blue mekhela, white blouse, maroon sweater or blazer and black footwear.

For B.Voc. students (Boys) - Formal white shirt and rest same as others.

For B.Voc. students (Girls) - White kameez, white salwar and blue dupatta.

5. *Scholarship*

The students of Mangaldai College are entitled to apply for the following scholarships as per rules:

1. National Merit Scholarship.
2. National Loan Scholarship.
3. State Merit Scholarship.

4. Merit cum Means Scholarship.
5. S.T./S.C./O.B.C./MOBC (As prescribed by the Project Director, ITDP) Scholarship.
6. Minority Scholarship.
7. Ishan Uday Scholarship (UGC).
8. Scholarships from Alumni Association
 - a. Scholarship for Best Science Graduate:
by Mr. Indra Koch, Ex. Student, Mangaldai College
 - b. Scholarship for Highest scorer in Geography:
by Mr. Krishna Kanta Saikia, Retd. Lecturer, Mangaldai College
 - c. Scholarship for Highest scorer in Mathematics:
by Mr. Anwar Hussain, Accounts Officer, PWD, Govt. of Assam
(In memory of Late Rousan Ara Begum)

6. *Awards:*

The college distributes awards for outstanding achievements in B.A./B.Sc final examinations in following categories

- i. Girish Chandra Memorial best Graduate award :
One Certificate and Cash money of Rs 10,000
- ii. Best Graduate in Geography
Donor- Mr. Krishna Saikia (Retd. HoD Dept. of Geography): One Certificate and Rs 5000
- iii. Best Graduate in Education
Donor- Dr. Usha Rani Deka, Asstt. Prof., Mangaldai College
- iv. Best Graduate in Math
Anowara Begum memorial,
Donor- Anowar Hussain (Retd. Accounts officer, PWD(R): One Certificate and Rs 5000.
- v. Best Graduate in Science
Donor- Indra Kanta Koch: One certificate and Rs 5000.
- vi. Bidyut Prabha Das Memorial Best Graduate award in Zoology,
Donor Dr. Barnali Das, Deputy Superintendent, Kalaigaon Model Hospital :
One certificate and cash money of Rs 5000/-

7. *Debate, Sports and Cultural Activities*

In our college, the authority not only gives high priority to the academic career of students but also attaches due importance to promotion of co-curricular activities. The students union with active support of in-charge teachers organize Swahid Memorial Debate competition on all Assam basis in the month of September where the competitors get a chance to debate on burning issues of society.

The student union also organizes college week in the month of January where students get the opportunity to participate in sports and cultural activities. Students also get the opportunity to represent the college in various sports and cultural events organized by different colleges, universities and other institutions.

8. *Sports facilities in College Campus*

The college has a well-maintained playground for cricket, football and other athletic activities. The College also has a basketball court, a gymnasium and other indoor games facilities. A swimming pool and an Indoor Stadium are under construction, completion of which will provide enormous scope to the students in sports activities.

9. *National Cadets Corps (N.C.C.)*

Students of Mangaldai College can join senior division NCC of boys' and girls' wing. On being enrolled they can appear in different examinations on completion of their training. There are three scholarships for the cadets of NCC. They are Best Cadet Scholarship, Cadet Welfare Scholarship and Shahara Scholarship. These Scholarships have different criterion for selection. Cadets of our college have the prospect of joining different State and National Level Camps which help them to learn leadership qualities. Students willing to join NCC must apply separately to the respective wings after admission.

CONTACT OFFICERS

Major Hariman Deka, Associate Prof., Geography for Senior Division (Boys)
Ms. Kuntala Sarma Bordoloi, Assistant Prof., Botany for Senior Division (Girls).

10. National Service Scheme (N.S.S.)

A student of Mangaldai College may join N.S.S. which gives an opportunity to develop his/her personality and shape his/her attitude towards life. Since the year of inception in 1972, this organization has undertaken several projects for social service and completed them successfully. Students willing to opt for NSS may contact the professor in charge of it

CONTACT OFFICER

Mr. Nabajyoti Doley, Assistant Professor, Department of Philosophy

11. Youth Red Cross, Mangaldai College unit (Indian Red Cross Society)

Youth Red Cross, Mangaldai College Unit was established in the year 2015 to conduct various social and health awareness programmes. Moreover, it also encourages the students to extend their humanitarian service to the society at the time of crisis.

CONTACT OFFICER:

Mr. Issa Ram Nath, Assistant Professor, Department of Political Science
Dr. Seema Jyoti, Associate Professor, Department of Zoology

12. Student Service Centre

This centre houses two cells- Career Counseling and Placement cell and the Coaching and Training cell. It provides following services to the students of the college,

- a) Career information in academic & professional fields.
- b) Organization of periodical career counseling programmes.
- c) Employment information.
- d) APSC/UPSC and other competitive Examination preparation training program.

13. SWAYAM-NPTEL Local Chapter:

SWAYAM-NPTEL Local Chapter is an initiative by the Government of India to provide a platform to young and bright students across India to learn multiple courses according to their interest from esteemed faculties of prestigious IITs through virtual mode. Mangaldai College is approved as a Local Chapter on 16 May 2023 and has become a part of this great initiative. The course runs throughout the year at different points of time comprising courses of 4 /6 /8 /12 weeks. The certificates are issued only after appearing in the final online exam. Internship is also offered for student toppers of NPTEL Online Certification Exams and there are also chances for students to get recruited. Students can earn and deposit credits in the Academic Bank of Credits (ABC), thus, boosting their confidence and getting a wing to fly high towards their dreams. A Single Point of Contact (SPOC) is assigned by NPTEL for proper coordination of the course in our college.

Details of Single Point of Contact (SPOC):

Krishna Das, Assistant Professor, Department of Zoology, Mangaldai College.

14. Mangaldai College Students' Union

Regular students of Mangaldai College may participate in the formation of students' union as per terms and conditions laid down by the authority and the Lyngdoh Commission. The union is elected annually by the regular students of the college on the terms and conditions laid down in the bye-laws framed for the purpose. The Principal of the College has the absolute right to suspend or dismiss any office bearer of the students' union or look into the activities of the students' union. The Principal of the College appoints a teacher in-charge in each section of the students Union.

15. CENTRAL LIBRARY:

Mangaldai College extends library facilities to the students and the teaching staff of the college. After getting admitted into the college a student is to apply with necessary documents to the college librarian to be a member of the college library and to get his/her borrowing cards. Students are asked to note the following points:

1. A student in undergraduate course will be issued three borrowing cards at the time of admission. On the other hand, students in higher secondary classes: two borrowing cards will be issued at the time of admission.
2. A student may borrow one book from the library against its card for a period not extending fifteen days. However, a book may be reissued for another fifteen days on special request.
3. Any damage, defacement or lost of a book invite disciplinary action and penalty charges against the borrower.
4. If a book is not returned within the due date, a borrower is to pay a fine of fifty paise per day from the due date to the date of return of the book.
5. All library books must be returned before the test/last terminal examination, otherwise the issue of admit cards or marksheets would be withheld in case of defaulting students.
6. Books may be recalled from the borrower in case of whenever it is needed.
7. Other facilities of central library:
 - a) Students/Teachers can search his/her books in our library through OPAC (Online Public Access Catalogue) facility. The OPAC facility is available in our website page www.mangaldaicollege-opac.in. Students can also access it through their mobile phones.
 - b) Students can also use the OPAC facility to read the e-books, e-journal and e-magazines.

16. Departmental Library

In addition to the General (Central) Library, each department of the college has a departmental library of its own. Students in the subject concerned may avail the opportunity of using the Departmental Library in accordance with rules and regulations framed by the department in concurrence with the decision of the Principal.

17. Assam Science Society, Mangaldai branch

With the objective of creating scientific temperament and popularizing science among students and communities, Assam Science Society, Mangaldai Branch was established on 29th April, 1971.

18. Alumni Association

The alumni association of the College holds periodic meetings among its members and keeps in touch with their alma mater/ Principal about the various activities of the college.

19. Hostel Advisory Committee

The committee looks after the hostel management system and its related issues.

20. Library Advisory Committee

The Library Advisory Committee looks after the management and development of the Library.

21. Students' Travelling Concession

Students of the College are entitled to railway concession to travel home and back during vacations and for travelling on academic tours conducted by the College.

22. Various Cells and Clubs

➤ **Women's Studies Research Cell**

This cell looks after the welfare of students (girls) and women employees of the College and its neighboring areas. It regularly conducts welfare activities on gender issues for empowering women.

➤ **Research and Development Cell**

This cell provides the platform for students and the faculty members alike to flourish creativity and innovation. It also encourages and offers guidance to faculty members to undertake various research projects.

- **Students Grievance Redressal Cell (SGRC)**
G.R.C. was established in 2003 for redressal of various grievances of the students, the faculty members and the staff of the College relating to the College affairs. The Complainants may submit their complaint/ grievances in the Complaints/Grievance Box or directly to Teacher i/c of the Grievance Redressal Cell.
- **Green Audit Committee**
The Green Audit Committee is entrusted with the responsibility to conduct the green audit of the college and prepare a report stating the details.
- **Feedback Committee**
All the Departments collect feedback from students, alumni, parents and faculty members and IQAC analyzes the data with the help of Feedback Committee.
- **College Website Management Committee**
The College Website Management Committee is entrusted with updating the college information on its website and also it looks after the development and maintenance.
- **The Anti-ragging Committee**
The Anti-ragging Committee of the college has the responsibility of keeping a sensitive and ragging free environment in the college campus. Students can approach the committee with their grievances regarding ragging and related issues.
- **Committee for prevention of Sexual Harassment**
This Committee is formed with the objective of maintaining a safe and secure environment for women students as well as faculty members inside the college campus. Any grievance regarding women's safety in college is taken as an utmost priority by this committee and an immediate solution of the problem is sought.
- **Vigilance Cell**
The Vigilance Cell is entrusted to monitor the regular college activities and its various assets to ensure a healthy ambience inside the college premise.
- **Coaching and Training cell**
The Coaching and Training cell is constituted to organize coaching and training programmes for the greater interest of the students. The cell will conduct various activities in this regard and would also keep a record of all the activities done by it.
- **Career Counselling and Placement Cell**
The Career Counselling and Placement Cell, Mangaldai College is aimed at providing proper career counseling to the students via counseling sessions. Moreover, the cell is going to initiate Placement drives for the benefit of the students.
- **NEP- 2020 Cell for Implementation of NEP-2020**
In light of the National Education Policy roll out, the NEP 2020 cell is constituted to chalk out an action plan for the implementation of the same in Mangaldai College. The cell is also entrusted with the responsibility to prepare the draft of the prospectus in the light of the regulations released by GU and the government of India.
- **ECO Club**
There is an eco-club in the college which aims to create awareness among the students and the public to keep the environment clean and green.
- **Sports Club**
The College sports club is entrusted with the responsibility to hold events and training of sports from time to time. It also focuses on creating a sports friendly environment in college premise.
- **National Digital Library of India (NDLI) Club**
The NDLI Club of Mangaldai College was approved by the NDLI on 30-05-2023. The Club was formed with a view to let the students know about the unique features of NDLI as a single-window search facility for all digital educational resources so that learners can retrieve the right resources with the least effort in minimum time. This digital learning platform also provides user group-specific services such as Examination Preparatory for School and College students and job aspirants (IBPS, RRB, SSC, UPSC). The Club organizes various events to boost the learning opportunities to students. A committee comprising of 5 members is assigned by the College authority for proper functioning of the Club.
- **Standard Club**
The Club was formed under the banner of Bureau of Indian Standards (BIS) with the intention of carrying out a variety of student-centric activities like debate, standard writing competition, quiz, seminar etc., aimed at providing

them opportunities for learning on the themes of Quality and Standardization. The main goal of the club is to make people appreciate the significance of quality, standards and standardization.

- **Youth Red Cross Cell**
Youth Red Cross Cell,

23. *College Hostel*

Mangaldai College has one Girls' Hostel. The hostel is situated on the eastern side of the college campus and equipped with all facilities. The selection for hostel seats is made on merit and reservation rules of the Govt. However, students coming from far off places, having no convenient transport and communication facilities, will be given preference in the allotment of a hostel seat. Students desirous of availing hostel accommodation will have to apply separately to the Hostel Superintendent along with the documents cited below:

1. Mark sheet of the last examination passed.
2. Caste Certificate from appropriate authority.
3. Two passport sized photographs.
4. Parent's / Guardian's declaration.

If admitted to the college hostel, a student must abide by the following rules:

- a. The boarder must pay her hostel mess dues on a monthly basis.
- b. No boarder shall leave the hostel premises without prior permission from the hostel superintendent.
- c. During study hour strict silence is to be observed and no outsider can enter into the hostel without prior permission of the hostel superintendent.
- d. No guest is allowed to be entertained without permission of the hostel superintendent.
- e. The visitors are allowed to meet a hostel boarder only in the visiting room within the visiting hour. Male visitors are strictly prohibited from entering inside the hostel.
- f. Hostel properties including building, furniture, utensils, electrical appliances etc. should be properly maintained and in case of any damage, it must be brought to the notice of the hostel superintendent.
- g. Use of unauthorized electrical appliances such as heaters, iron etc. is prohibited.
- h. Case of indiscipline and non-compliance with hostel and college rules shall be severely dealt with, leading to even expulsion from the hostel if necessary.
- i. Expulsion from college entails expulsion from hostel and vice-versa.
- j. The college hostel remains closed during summer and puja vacation. However, in case of examination during vacation, arrangement of mess is made at the hostel.



24. College Fee Structure

FEES CHART 2023-2024
MANGALDAI COLLEGE, MANGALDAI

Sl. No.	Particulars	HS-I		H.S-II		TDC 1 st yr (1 st & 2 nd Sem.)		TDC 2 nd Yr. (3 rd & 4 th sem.)		TDC 3 rd yr. (5 th & 6 th sem.)	
		Arts	Sc	Arts	Sc.	Arts	Sc.	Arts	Sc.	Arts	Sc.
1	Admission	500	500	500	500	500	500	500	500	500	500
2	a)Tution Fees General	600	720	600	720	720	840	720	840	720	840
	b) Tution Fees Major	0	0	0	0	120	180	120	180	120	180
	c) Major admission	0	0	0	0	100	100	100	100	100	100
3	College development	300	300	300	300	300	300	300	300	300	300
4	Infrastructure	300	300	300	300	300	300	300	300	300	300
5	Auditorium	100	100	100	100	100	100	100	100	100	100
6	Electricity	350	350	350	350	350	350	350	350	350	350
7	Drinking water	10	10	10	10	10	10	10	10	10	10
8	Examination (Internal)	200	200	200	200	250	300	250	300	250	300
9	Certificate	25	25	25	25	25	25	25	25	25	25
10	Library & Library Development	200	200	200	200	200	200	200	200	200	200
11	Library caution	100	100	100	100	100	100	100	100	100	100
12	Identity card	25	25	25	25	25	25	25	25	25	25
13	Students welfare	100	100	100	100	100	100	100	100	100	100
14	Campus development	300	300	300	300	300	300	300	300	300	300
15	NSS/NCC/Scouts and Guides	30	30	30	30	30	30	30	30	30	30
16	Laboratory caution	75	100	75	100	75	100	75	100	75	100
17	Laboratory fees	300	400	300	400	300	500	300	500	300	500
18	Laboratory contingency	200	300	200	300	250	300	250	300	250	300
19	Faculty development	400	400	400	400	400	400	400	400	400	400
20	Council registration	100	100	0	0	0	0	0	0	0	0
21	Council Enrollment	25	25	50	50	0	0	0	0	0	0
22	Affiliation	50	50	50	50	150	150	150	150	150	150
23	IQAC	100	100	100	100	100	100	100	100	100	100
24	Union fees	40	40	40	40	40	40	40	40	40	40
25	Festival fees	50	50	50	50	50	50	50	50	50	50
26	Union Misc Fees	10	10	10	10	10	10	10	10	10	10
27	Magazine	100	100	100	100	100	100	100	100	100	100
28	Game Fees	30	30	30	30	30	30	30	30	30	30
29	Youth Festival	35	35	35	35	35	35	35	35	35	35
30	Music & Culture	30	30	30	30	30	30	30	30	30	30
31	Social service	10	10	10	10	10	10	10	10	10	10
32	Debates & Talk a) General	20	20	20	20	20	20	20	20	20	20
	b) Inter college competition	30	30	30	30	30	30	30	30	30	30
33	Common Room	20	20	20	20	20	20	20	20	20	20
34	Gymnasium	20	20	20	20	20	20	20	20	20	20
35	Fine Arts	5	5	5	5	5	5	5	5	5	5
36	Literary Section	5	5	5	5	5	5	5	5	5	5
37	ICT	100	100	100	100	100	100	100	100	100	100
38	College Contingency	150	150	150	150	150	150	150	150	150	150
		5045	5390	4970	5315	5460	5965	5460	5965	5460	5965

(N.B Students who wants to opt for Computer Science as a minor subject will have to pay Rs 2000 per year as laboratory fees.)

25. **HOSTEL FEES**

Hostel Admission : Hostel Admission Forms will be provided by the College Office on the day of admission and applicants must submit them to the Principal's office, Mangaldai College.

A non-refundable admission fee must be paid at the time of admission for the session.

A sum of ₹ 300/- (Rupees Three Hundred) only is to be deposited as hostel caution money at the time of admission to the Superintendent. The caution money is refundable.

- N.B.**
- A boarder admitted will have to pay current mess dues as fixed by the mess committee to the hostel.
 - A guest boarder who stays during time of examination only (with prior permission of the college authority and hostel superintendent) is to pay a seat rent of ₹ 500.00 to the college if the stay is for less than one month.
 - Any student staying in the hostel for more than one month will be treated as a regular boarder.
 - A guest boarder will have to pay mess dues on a day-to-day basis as fixed by the mess committee and such dues will have to be paid to the hostel superintendent.

COLLEGE ADMINISTRATION

The Administration of Mangaldai College is carried forward by the Governing Body of the college with various directions, instructions, guidelines of the Director of Higher Education, Govt. of Assam, the Gauhati University, the University Grants Commission and other Central and State Government agencies.

1. **GOVERNING BODY**

President	:	1.	Mr. Ramani Kanta Saharia. M.A
Secretary	:	2.	Dr. Kamala Kanta Borah, M.Sc, Ph.D., Principal.
Members	:	3.	Dr. Sanjay Deka, GU Nominee
		4.	Mr. Bhabesh Narayan Choudhury, GU Nominee
		5.	Mr. Ramesh Sarmah (Guardian Member)
		6.	Mr. Ramen Ch Deka (Guardian Member)
		7.	Mrs. Hiranya Prava Nath (Guardian Member)
		8.	Sri Mukul Deka (Donor Member)
		9.	Dr. Anupam Thakuria (Teachers' Representative)
		10.	Mr. Pranab Das (Teachers' Representative)
		11.	Mr. Amarendra Rajkhowa, Sr. Asstt. (Member from Non-Teaching Staff)
		12.	Mr. Basanta Das, Special Invitee Member as Local MLA
		13.	Mrs. Khanjana Deka (Librarian, Mangaldai College)

2. **Administrative Office**

Since its inception, the administrative office has consistently been the hub of administrative activities in our college. Currently, a team of five individuals efficiently manages the office, each assigned with varying workloads.

3. **DEPARTMENTS AND ACADEMIC STAFF**

The faculty members of the College are not only devoted to their profession but also are keen to see the College flourish with brilliant performance of the students. All the teachers are endowed with extra-curricular abilities to help the students in diverse fields of games and sports, music, culture, social service and extension education. All the teachers are helpful to the students both in and outside the classroom to bring out the talent in them.

PRINCIPAL

Dr. Kamala Kanta Borah, *M.Sc, Ph.D.*

DEPARTMENTS & FACULTY MEMBERS

- Department of Arabic :**
1. Dr. Abul Qasim, M.A., M.M., B.Ed., M.Phil., Ph.D. Assistant Professor (HOD)
 2. Dr. Amir Hussain, M.A, Ph.D., Assistant Professor
- Department of Assamese :**
1. Mr. Dimbeswar Baruah, M.A., Associate Professor (HOD)
 2. Dr. (Mrs) Barnali Kalita, M.A., Ph.D., Associate Professor
 3. Dr. (Mrs) Rupjyoti Baruah, M.A., Ph.D., Associate Professor
 4. Dr. (Mrs) Saraju Priya Devi, M.A.,M.Phil, Ph.D., Associate Professor
 5. Ms. Dipti Das, M.A., Assistant Professor
 6. Mr. Chitraranjan Nath, M.A., Assistant Professor
- Department of Bengali :**
1. Mousumi Kansa Banik, M.A., M.Phil., Assistant Professor (HOD)
- Department of Bodo :**
1. Mr. Phakhon Brahma, M.A, B.Ed, Assistant Professor (HOD)
 2. Mr. Durgeswar Baro, M.A., Assistant Professor (Cont.)
 3. Mr. Kamal Daimary, M.A., Assistant Professor (Cont.)
- Department of Botany :**
1. Dr. (Mrs.) Prativa Deka, M.Sc, M.Phil., Ph.D., Associate Professor (HOD)
 2. Dr. Sahabuddin Ahmed, M.Sc, B.Ed., M.Phil., Ph.D., Assistant Professor
 3. Dr. DebashreeKakati, M.Sc., Ph.D., M, Phil, B.Ed., Assistant Professor
 4. KuntalaSarmahBordoloi, M.Sc, Assistant Professor
 5. Dr. Rajreepa Talukdar, M.Sc., Ph.D, Assistant Professor
 6. Mr. ManashPratim Baruah, M.Sc., Assistant Professor
 7. Mr. Rahul Malakar, M.Sc., Assistant Professor
- Department of Chemistry:**
1. Dr. Atul Prasad Sikdar, M.Sc, Ph.D., Associate Professor (HOD)
 2. Dr. Kamala Kanta Borah, M.Sc,Ph.D., Associate Professor (in lien)
 3. Dr. Swah Mohd. Nashre-ul-Islam, M.Sc, Ph.D., Assistant Professor
 4. Dr. Pankaj Kumar Ghosh, M.Sc, Ph.D., Assistant Professor
 5. Dr. PallabiSaikia, M.Sc., Ph.D, Assistant Professor
 6. Ms. Priya Sonowal, M.Sc., Assistant Professor
- Department of Economics:**
1. Dr. (Mrs.) Chandrama Goswami, M.A., B.Ed., Ph.D., Asso Prof. (in lien)
 2. Dr. Santosh Barkakati, M.A., Ph.D, Assistant Professor (HOD)
 3. Mr. Umesh Chandra Sarma, M.A., B.Ed., Assistant Professor
 4. Ms. Dreamly Sarmah, M.A., Assistant Professor
- Department of Education :**
1. Dr. Babita Sharma, M.A., M.Phil., Ph.D., Associate Professor (HOD)
 2. Dr. Usha Rani Deka, M.A., M.Phil., Ph.D., Assistant Professor
 3. Dr. Kunjalata Baruah, M.A., B.Ed., Ph.D., Assistant Professor
- Department of English :**
1. Dr. Runjun Devi, M.A., Ph.D., Associate Professor (HOD)
 2. Mrs. Ruparani Bhuyan, M.A., Assistant Professor
 3. Ms. Neha Mahanta, M.A., Assistant Professor
 4. Mr. Suhail Mohammed, M.A., Assistant Professor

- Department of Geography:**
1. Dr. Pabitra Kumar Nath, M.A., B.Ed., Ph.D., Associate Professor (HOD)
 2. Maj. Hariman Deka, M.A. (Double), Associate Professor
 3. Dr. Mukut Sarma, M.A., B.Ed., M.Phil., Ph.D., Assistant Professor
 4. Dr. Jayanta Kumar Baruah, M.A., Ph.D., Assistant Professor
 5. Dr. Pranjit Kr. Sarma, M.A., B.Ed., Ph.D., Assistant Professor
 6. Mrs. Deepa Pradhan, M.Sc., Assistant Professor
- Department of History :**
1. Dr. Angiras, M.A., LL.B., Ph.D., Associate Professor (HOD)
 2. Dr. Sangeeta Gogoi, M.A., B.Ed., Ph.D., Associate Professor
 3. Dr. Mridul Deka, M.A., B.Ed., M.Phil., Ph.D., Assistant Professor
- Department of Mathematics :**
1. Mr. Debajit Nath, M.Sc, Associate Professor (HOD)
 2. Mr. Dimbeswar Kalita, M.Sc, M.Phil., Assistant Professor
 3. Mr. Jintu Mani Nath, M.Sc., Assistant Professor
- Department of Philosophy :**
1. Sri Bhupen Haloi, M.A., Associate Professor (HOD)
 2. Dr. (Mrs.) Manju Kalita, M.A. M.Phil., Ph.D., Assistant Professor
 3. Mr. Nabajyoti Doley, M.A., Assistant Professor
 4. Ms. Sagarika Thaosen, M.A., Assistant Professor
- Department of Physics :**
1. Dr. Ranjan Sarma, M.Sc, M.Phil, Ph.D., Assistant Professor (HOD)
 2. Dr. Kangkan Sarma, M.Sc, B.Ed., Ph.D., Assistant Professor
 3. Dr. Ananya Phukan, M.Sc, Ph.D., Assistant Professor
 4. Ms. Chayanika Rabha, M.Sc., Assistant Professor
 5. Ms. Saraswati Devi, M.Sc, Assistant Professor
 6. Vacant
- Department of Political Science :**
1. Mr. Issa Ram Nath, M.A., M.Phil., Assistant Professor (HOD)
 2. Dr. Barnali Deka, M.A., B.Ed., M.Phil., Ph.D., Assistant Professor
 3. Dr. Anupam Thakuria, M.A., Ph.D., Assistant Professor
- Department of Sanskrit :**
1. Mr. Gagen Kakati, M.A., M.Phil., Assistant Professor (HOD)
 2. Dr. Arpana Devi, M.A., B.Ed., M.Phil., Ph.D., Assistant Professor
- Department of Statistics :**
1. Dr. Ranjita Goswami, M.Sc, M.Phil., Ph.D., Assistant Professor (HOD)
 2. Mr. Pranab Das, M.Sc, M.Phil., Assistant Professor
 3. Vacant
- Department of Zoology :**
1. Dr. Minati Sarma, M.Sc, B.Ed., Ph.D., Associate Professor (HOD)
 2. Dr Seema Jyoti, M.Sc, B.Ed., M.Phil., Ph.D., Associate Professor
 3. Mr. Bikash Rabha, M.Sc., Assistant Professor
 4. Mrs. Pritimoni Das, M.Sc., Assistant Professor
 5. Ms. TunujaBoro, M.Sc., Assistant Professor
 6. Ms. Krishna Das, M.Sc., Assistant Professor
- Department of Comp. Science :**
1. Mr. Deepjyoti Kalita, M.Sc, Assistant Professor (Cont.)(HOD)
 2. Mr. Hire Deka, MCA, Assistant Professor (Cont.)
 3. Mr. Abhijit Baruah, MCA, Assistant Professor (Cont.)
- Dept. of B.Voc.**
1. Mr. Lakhya Jyoti Gogoi, M.Sc. (Biotech.) Assistant Professor (Cont.) (HOD)
 2. Mrs. Himakshi Baishya, M.Tech. (F.P. Technology) Assistant Professor (Cont.)

NON-TEACHING STAFF

- Library :
1. Mrs. Khanjana Deka, M.L.I. Sc, B.Ed., M.Phil., Librarian
 2. Mr. Santanu Kr. Baruah, B.A., Library Bearer
 3. Mr. Biswajit Deka, H.S., Library Bearer

- Administrative Office :
1. Head Assistant (Vacant)
 2. Md. Saidur Rahman, Senior Assistant
 3. Mr. Amarendra Rajkhowa, B.A., Senior Assistant
 4. Mr. Surajit Kumar Nath, B.A., Laboratory Assistant
 5. Md. Samsuddin Ahmed, B.A., Junior Assistant
 6. Mr. Kushal Goswami, M.A., PGDCA, Library Assistant
 7. Vacant (Junior Assistant)
 8. Vacant (Junior Assistant)
 9. Vacant (Junior Assistant)
 10. Vacant (Junior Assistant)
 11. Vacant (Junior Assistant)

GRADE IV :

- Peon :
1. Mr. Hari Chandra Deka, Peon
 2. Mr. Dimbajyoti Baro
 3. Mr. Manoj Baruah
 4. Mr. Bhabesh Bania
 5. Mr. Jamuna Sharma

- Laboratory Bearer :
1. Mr. Bhadr Lal Jadav, Lab. Bearer
 2. Md. Mafidul Islam, Lab. Bearer
 3. Mr. Makhan Ch. Sarma, Lab. Bearer
 4. Mr. Gajen Baro, Lab. Bearer
 5. Mr. Pranab Hazarika, Lab. Bearer
 6. Mr. Tilak Deka, Lab. Bearer
 7. Mr. Bhaskar Jyoti Deka, Lab. Bearer
 8. Mr. Rupam Rajkhowa, Lab. Bearer
 9. Mr. Bipul Sarma, Lab. Bearer

INTERNAL QUALITY ASSURANCE CELL (IQAC)

The Internal Quality Assurance Cell (IQAC) is an integral part of Mangaldai College, ensuring and enhancing the quality of education and academic processes. It serves as a nodal agency for coordinating quality-related activities, driving institutional quality improvement, and facilitating the accreditation process.

The IQAC is mandated to develop and implement a robust quality assurance system that fosters continuous improvement in all aspects of our institution's functioning. It works towards maintaining academic standards, monitoring teaching-learning processes, and evaluating the overall effectiveness of our educational programmes.

Its primary objectives include:

- Developing and implementing quality benchmarks for academic and administrative activities
- Facilitating the dissemination of information on various quality parameters
- Organising workshops, seminars, and training programs to enhance the competence of faculty and staff
- Organising students' capacity building programmes
- Collecting and analysing feedback from stakeholders for continual improvement
- Initiating and promoting innovative practices in teaching and learning
- Ensuring the effective functioning of the feedback mechanism
- Conducting Academic and Administrative Audits, Environment Audit, Green Audit, etc.
- Preparing and submitting Annual Quality Assurance Reports (AQARs) and Self Study Report (SSR)

Through the IQAC, we aim to create an environment that fosters academic excellence, creativity, innovation, and effective governance. We are committed to aligning our efforts with the vision and mission of our institution, striving for continuous improvement, and benchmarking ourselves against the best practices in the field of higher education.

We invite you to explore the IQAC's initiatives and resources to gain insights into our quality assurance processes. Your feedback, suggestions, and involvement are crucial in our collective pursuit of excellence.

Dr Santosh Borkakati
Coordinator, IQAC
Mangaldai College

POST GRADUATE PROGRAMME

The Gauhati University accorded permission to open P.G. Classes in Assamese from 1995-96 Session. The course is a self-financed one.

1. Duration of Course

The P.G. Programme comprises of four semester examinations for the two-year programme.

2. Rules for admission

Admission will be based on the result of centrally conducted entrance test of the GU.

- i) The candidate will have to apply in the prescribed form obtainable from the college office on payment of prescribed fee.
- ii) Following certificates/testimonials are to be attached along with the duly filled up application forms.
 - a) Attested copies of marksheets from H.S.L.C. examination onwards.
 - b) Attested copies of Caste certificates issued by the competent authority where it is necessary.
 - c) Attested copies of H.S.L.C. certificate or admit card for age verification.
 - d) Attested copies of conduct and character certificate from the Head of the institution last attended.
 - e) Gap certificate must be produced if necessary.
 - f) Two recent passport size photographs, one with signature of the applicant to be pasted on the application form (in the space provided) and the other one for the issue of identity card.
- iii) The selected candidates are to submit certificates/testimonials in original at the time of admission. Submission of wrong information or suppression of facts in any form results in forfeiture of the seat at any time.
- iv) Students admitted to a course of study are to abide by all the rules, regulations, orders, etc., Failure of which will call for disciplinary action.

3. Selection and Admission

List of Candidates selected for admission will be displayed on the Notice Board and they will have to get themselves admitted on the date and time notified.

4. Functioning of classes

Classes will be held in accordance with the class routine to be notified in due course.

5. Attendance

75% Attendance in P.G. class is compulsory. If any student fails to attend at least 75% of the classes held he/she may be debarred from appearing in the examination.

6. Cancellation of seat

A student failing to attend classes for 30 consecutive working days in any semester shall forfeit his/her seat.

7. **Library**

Students of P.G. classes will be eligible to use the college library as per rule.

8. **Hostel accommodation**

Hostel seat on admission is not guaranteed. Besides merits, Girl's Students coming from long distance may be one of the criteria for selection for the hostel seats.

9. **Admission Fee**

At the time of admission a student will have to pay a sum of ₹14000/- (Rupees Fourteen thousand) only as admission fee and ₹ 500 (five hundred) as Library caution money for one academic year.

Extension Activities

Since the college is situated in an underdeveloped part of the state it is but natural on parts of its authority to take interest in all round development of the people residing here. Thus the faculty members and the students of this college make trips to nearby villages to conduct such programme like cleanliness drives, organized blood donation camps and encourage people to go for cashless transactions. It could also be noted here that faculty members sometimes go to nearby schools to take classes on particular topics and thereby encourage the students there to find more interest in their studies.

KRISHNA KANTA HANDIQUI STATE OPEN UNIVERSITY STUDY CENTRE

The study centre of the above said open university has been imparting quality education ever since its establishment. The students who could not take advantage of the system of the formal education for different reasons have enrolled themselves at the study center for higher education. At present the centre is conducting BA, Degree in Mass Communication and BPP (Bachelor Preparatory Programme) courses. The students who could not clear matriculation can also aspire for higher education by clearing BPP.

Eligibility

BPP : Candidates who have not completed HSLC or HSSLC Examination but attained 18 years of age or above

B.A./BMC : Candidates who have passed HSSLC Examination (10+2) in any stream and those who have passed relevant BPP course of KKHSU.

PG Courses Under K.K.H.S.O.U.

Post Graduate Courses are being offered by K.K.H.S.O.U. under the following subjects:

Subject : Assamese, Education, English, Sociology, Economics, and Political Science

Eligibility : Graduate from any University

For Admission

Contact- Mr. Dimbeswar Baruah, M.A.,
Associate Professor & HOD, Department of Assamese (Coordinator).
KKHSOU, Study Centre, Mangaldai College. Phone- 9435519480

SANSKRIT EDUCATION

Mangaldai College provides an opportunity to all those who are interested in 'Sanskrit' to join non-formal courses on this subject which are offered by Rashtriya Sanskrit Sansthan, New Delhi. These courses are Prathama Diksha and Dvitiya Diksha. The details about these courses are given in the following-

A. It is a part time course.

B. Duration of the course is from August to April.

C. Courses of Studies

- i) Prathama Diksha (First Level)- Under it, the book Vakya-vyavaharah is taught in simple Sanskrit for a period of three months. A minimum period of 40 hours is required to complete the course.
- ii) Dvitiya Diksha (Second Level)- Through Sanskrit Subhashit as, stories and different types of special exercises compiled in Vyavahara-pradeepah, Simple Sanskrit grammar is taught in 5 months. A minimum period of 70 hours is required for this course.
- iii) Reading material (First Level and Second Level) will be provided free of cost by the Rashtriya Sanskrit Sansthan, New Delhi.
- iv) This Course will provide basic knowledge for higher studies in Sanskrit/Yoga/Ayurveda/various Distance Education Programmes of Rashtriya Sanskrit Sansthan.

Eligibility for Admission

Any person desirous of Sanskrit learning is eligible for admission to this course. In addition to the students, teachers, employees and officers of the concerned institution, admission is also open for general public.

Enrollment

Learners are required to submit their application form in the Centre and should deposit Rs. 350/- (Three Hundred Fifty) only as Enrolment fee for the Course through NEFT to Rashtriya Sanskrit Sansthan, New Delhi (A/C No. 10669781338, IFSC- SBIN0000733, Bank name- SBI Delhi Cantonment, Delhi or should deposit the fee with the Authorized Officer (Hod, Dept. of Sanskrit, Mangaldai College) of the centre. The Authorized Officer of the Centre will have to deposit the collected fee in Sansthan bank account through NEFT.

Examination

The examination will be conducted by Rashtriya Sanskrit Sansthan, New Delhi at the end of the course and the certificates will be given to the successful learners.

N.B.- Continuation of the Sanskrit courses given above are subjects to clearance by Rashtriya Sanskrit Sansthan.

FACILITIES IN THE COLLEGE CAMPUS

Canteen :	The College canteen remains open from 9-00 am to 4-30 pm. It makes available healthy and nutritious refreshment at reasonable rate to all customers.
College Gymnasium :	The students of this college can make use of the gymnasium at its scheduled hours.
College auditorium :	The College has a spacious auditorium for cultural activities.
Drinking water :	The College provides safe drinking water to all students and teachers round the clock.
Health care facilities :	The College makes arrangements for providing urgent medical care to its students and other members on a priority basis round the clock. It also organizes health check-up and blood-donation camps regularly in the campus.
Internet Facility :	The College provides Free Internet facilities(in selected programs) to all students and teachers of this college in the campus with a high speed connectivity of 50mbps.

**ONLINE ADMISSION FORM FILLUP PROCEDURE
FOR THE SESSION 2023-24
MANGALDAI COLLEGE, MANGALDAI**

Before filling up the online Admission form please ensure that you have the following documents ready

- 1) Passport sized Photo (400px X 500px), Maximum size: 300 KB.
- 2) Scanned Copy of Mark sheet of Last Examination Passed, Maximum Size: 500 KB.
- 3) Scanned Copy of HSLC Admit Card, Maximum size: 500 KB.
- 4) Scanned Copy of Caste Certificate (if belong to any), Maximum Size: 500 KB.

Procedure:

- 1) Proceed for registration by providing a valid own email ID, Mobile Number and New Password for Registration.
- 2) After providing necessary details, kindly login by using password which is created by the applicant during the time of registration.
- 3) After logging, read the instructions provided carefully.
- 4) For necessary information click on download link prospectus.
- 5) Go to the link www.mangaldaicollegeonline.co.in
- 6) Red asterisk fields are compulsory.
- 7) After filling the Form click on "Review Form" button to review the form and make corrections if required.
- 8) After successful review click on "Submit Button".
- 9) After submission, take a Print out of the Admission Form and Annexure for submission to College office after admission.
- 10) Admission will be held Offline on due course of time.
- 11) For any technical problem please mail to mangaldoicollege@gmail.com.
- 12) Candidates have to apply in "SAMARTH PORTAL" also.

